

FERRO[®]

NEW

REGULATING POPPET
VALVE

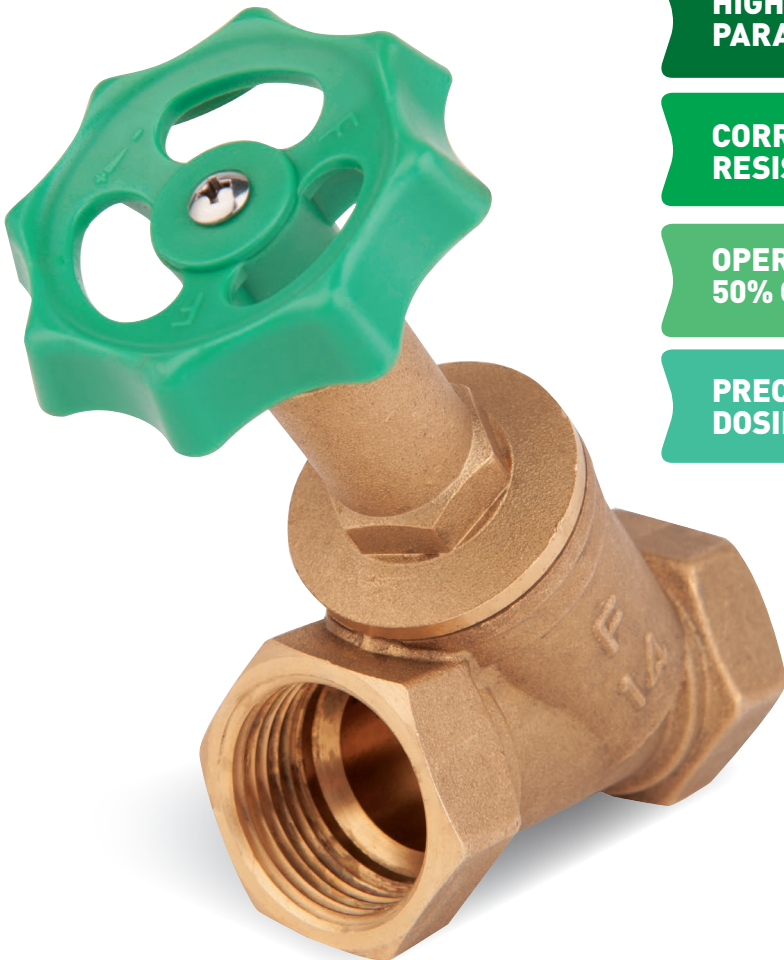

**HIGH WORKING
PARAMETERS**

**CORROSION
RESISTANT**

**OPERATES WITH
50% GLYCOL ETHYL**

**PRECISE WATER
DOSING**

REGULATING POPPET VALVE

- Higher working parameters than in cast iron valves.
- Solid corrosion resistant brass body.
- Skewed valve head allowing precise water dosing with minimum valve opening.
- Replaceable valve head.

NEW

H₂O | **GLYCOL**
50%

Mounted in:

- cold water systems
- central heating
- domestic hot water
- solar installations [up to 50% ethylene glycol]

• operating pressure

- for cold water up to 25 bars
- for central heating up to 10 bars

• operating temperature

- max. 120°C
- recommended up to 100°C

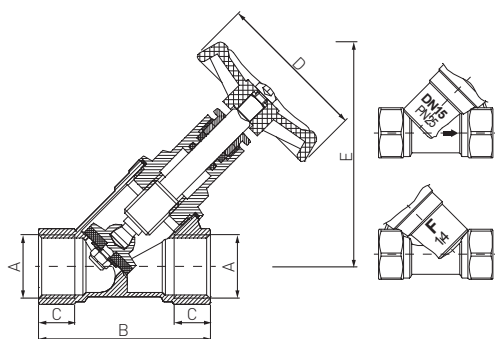

	DN	A	B [mm]	C [mm]	Ø D [mm]	E [mm]
ZGR01	15	G 1/2"	57	12	50	74
ZGR02	20	G 3/4"	68	13	50	82
ZGR03	25	G 1"	80	17	60	99
ZGR04	32	G 1 1/4"	92	16,3	60	108
ZGR05	40	G 1 1/2"	102	19,8	80	129
ZGR06	50	G 2"	122	21,3	80	145