

Code: GM2F-60GPA

Mixing group GM2F - with electronic pump 25-6-130 GPAII

<https://www.ferrocompany.com/product-5719-GM2F60GPA.html>

Individual packaging: **1, package with bar code allowing for retail sale**

Collective packaging: -

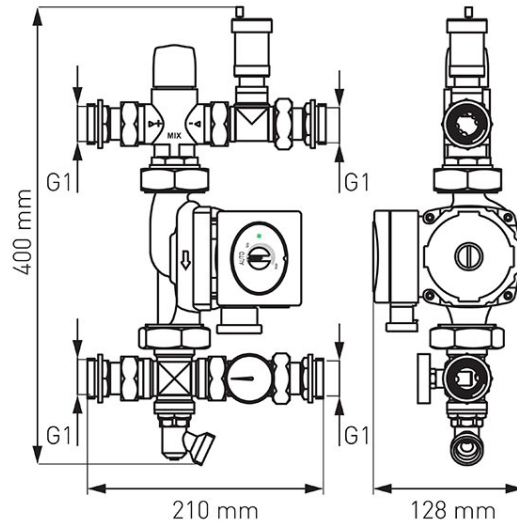

- The dual-function mixing group allows to lower and maintain the desired temperature of the heating agent of the surface heating system and connects it with the high-parameter radiator system.
- Technical parameters:
 - Static pressure (PN): max. 0,4 MPa (4 bar)
 - Dynamic working pressure: max. 0,3 MPa (3 bar)
 - Flow factor Kv: 1,9 m³/h
 - Temperature regulation range: 20-40°C
 - Accuracy of regulation: +/- 3°C
- The group contains:
 - 3-way thermostatic mixing valve
 - Automatic air vent with stop valve
 - Thermometer
 - Swivel drain valve
 - Set of unions
- Advantages:
 - double function – allows to connect radiator and floor distributors into a single system
 - Universal group for all types of manifolds with 210 mm bar spacing
 - Precise and simple control
 - Reversible