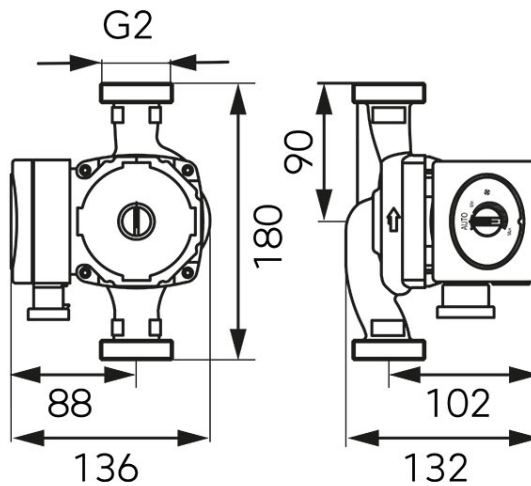

Code: 0607W

GPA II 32-8-180 Circulation pump

<https://www.ferrocompany.com/product-5362-0607W.html>Individual packaging: **1, package with bar code allowing for retail sale**Collective packaging: **4**

- operating range: max. 5.0 m³/h
- lifting height: max. 8 m
- liquid temperature: min. +2°C, max. +110°C
- application: Clean, free of solids, fibres and mineraloily substances, non-adhesive, chemically neutral, non-corrosive and non-explosive, with parameters similar to that of water. Pumping in liquids of a viscosity significantly higher than water will cause significant deterioration of the operating parameters, the pump may not operate properly. The pump can be used with a glycol concentration of up to 30%, and in such cases the pump will operate at a reduced efficiency.
- minimal inlet pressure depending on the liquid temperature: 0.50 bar (up to 85°C), 0.28 bar (up to 90°C), 1.00 bar (up to 110°C)
- maximum pressure: 10 bar
- protection class: IP 42
- Insulation class: H
- energy Efficiency Index: ≤0.23
- Installation: with the shaft in a horizontal position,
- cable gland pointing down or to the side
- voltage: ~230 V (-6% - +10%), 50/60 Hz
- power consumption: 5 - 70 W; 0,05 - 0,52 A
- connection spacing: 180 mm
- connection: G2
- ambient parameters: 0°C - 40°C; RH <95%