

Code: **KMH**

Herkules ball valve type V17

<https://www.ferrocompany.com/product-4352-KMH.html>

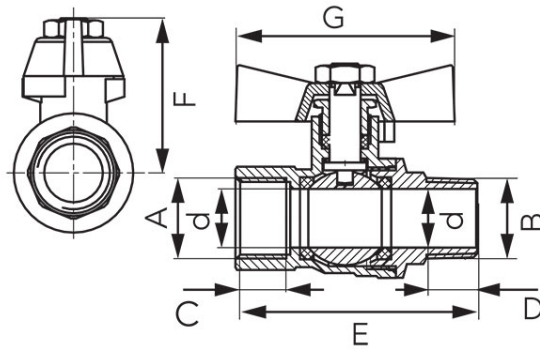

- 15 years warranty
- NICKEL FREE - all product elements which may have contact with potable water are not covered with nickel
- media valves:
 - water
 - 50% glycol
 - compressed air
- female - male
- full bore
- reinforced
- with a gland and double stem seal
- handle: metal butterfly
- body and ball material: brass
- material of ball and stem seals: PTFE
- nominal pressure: 4,0 MPa (40 bar)
- maximum working temperature: 140°C

Index	Size of connectors	DN	A	B	C [mm]	D [mm]	d [mm]	E [mm]	F [mm]	G [mm]	Individ. pack.	Bulk pack.	R*	E*
KMH11	1/2"	15	Rp ½	R ½	13	13	15	61,5	40	~56	12	144	KMH11W	KMH11E
KMH21	3/4"	20	Rp ¾	R ¾	14,5	14,5	20	70	46,5	~66	9	81	KMH21W	KMH21E
KMH31	1"	25	Rp 1	R 1	16,8	16,8	25	81,5	51	~72	8	64	KMH31W	KMH31E

***R - Product in individual packaging with EAN code enabling retail sale.**

***E - Products on euro-slot with barcode enabling retail sale (Eurohanger).**