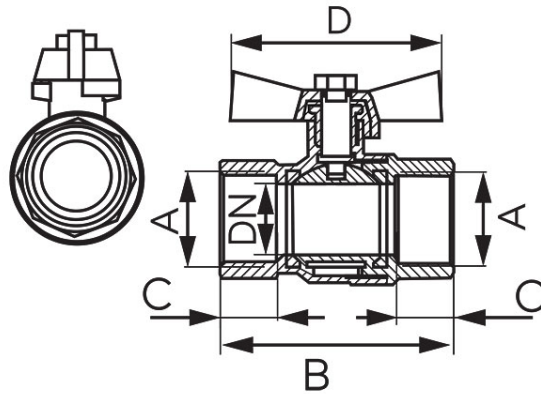

Code: **KMH**

Herkules ball valve type V17

<https://www.ferrocompany.com/product-4351-KMH.html>

- 15 years warranty
- NICKEL FREE - all product elements which may have contact with potable water are not covered with nickel
- media valves:
 - water
 - 50% glycol
 - compressed air
- female - female
- full bore
- reinforced
- with a gland and double stem seal
- handle: metal butterfly
- body and ball material: brass
- material of ball and stem seals: PTFE
- nominal pressure: 4.0 MPa (40 bar)
- maximum working temperature: 140°C

Index	Size of connectors	DN	A	B [mm]	C [mm]	D [mm]	Individ. pack.	Bulk pack.	R*	E*
KMH1	1/2"	15	Rp 1/2	56	13	~56	12	144	KMH1W	KMH1E
KMH2	3/4"	20	Rp 3/4	66	14,5	~66	9	81	KMH2W	KMH2E
KMH3	1"	25	Rp 1	76	16,8	~72	8	64	KMH3W	KMH3E

***R - Product in individual packaging with EAN code enabling retail sale.**

***E - Products on euro-slot with barcode enabling retail sale (Eurohanger).**